

INNOVATORS IN BRUSH TECHNOLOGY

FLEX-HONE® for CHAMFER BLENDING

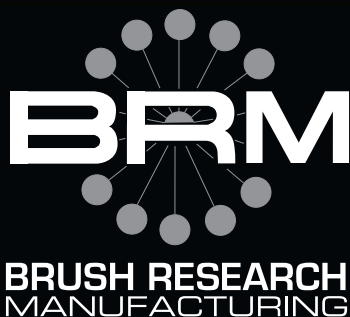

Brush Research Manufacturing presents the newest innovation in the continuing evolution of our Flex-Hone® technology: Flex-Hone for Chamfer Blending. This unique Flex-Hone design has the ability to blend and radius sharp edges and remove microburrs on chamfered holes eliminating stress risers caused by the chamfering operation. The Flex-Hone for Chamfer Blending comes in a variety of grit sizes and abrasive types and is suitable for finishing titanium, inconel, super CVM and nickel based stainless steel alloys. This tool eliminates hand finishing operations and produces consistent finishes from hole to hole, part to part.

www.brushresearch.com

FLEX-HONE[®] for CHAMFER BLENDING



Order by Bore Size

Nominal Bore Diameter	Nominal Bore With 0.005-.015 CHAMFER		Nominal Bore With .015-.030 CHAMFER		Nominal Bore With .030-.050 CHAMFER	
mm (inches)	PART ID	PART DESCRIPTION	PART ID	PART DESCRIPTION	PART ID	PART DESCRIPTION
4mm (.157)	CHA4M18	CH-A 4MM SMALL CHAMFER 180SC	CHB4M18	CH-B 4MM MEDIUM CHAMFER 180SC	CHC4M18	CH-C 4MM LARGE CHAMFER 180SC
4.5mm (.177)	CHA45M18	CH-A 4.5MM SMALL CHAMFER 180SC	CHB45M18	CH-B 4.5MM MEDIUM CHAMFER 180SC	CHC45M18	CH-C 4.5MM LARGE CHAMFER 180SC
4.75mm (.187)	CHA31618	CH-A 3/16" SMALL CHAMFER 180SC	CHB31618	CH-B 3/16" MEDIUM CHAMFER 180SC	CHC31618	CH-C 3/16" LARGE CHAMFER 180SC
5mm (.197)	CHA5M18	CH-A 5MM SMALL CHAMFER 180SC	CHB5M18	CH-B 5MM MEDIUM CHAMFER 180SC	CHC5M18	CH-C 5MM LARGE CHAMFER 180SC
5.5mm (.217)	CHA55M18	CH-A 5.5MM SMALL CHAMFER 180SC	CHB55M18	CH-B 5.5MM MEDIUM CHAMFER 180SC	CHC55M18	CH-C 5.5MM LARGE CHAMFER 180SC
6mm (.236)	CHA6M18	CH-A 6MM SMALL CHAMFER 180SC	CHB6M18	CH-B 6MM MEDIUM CHAMFER 180SC	CHC6M18	CH-C 6MM LARGE CHAMFER 180SC
6.4mm (.250)	CHA64M18	CH-A 6.4MM SMALL CHAMFER 180SC	CHB64M18	CH-B 6.4MM MEDIUM CHAMFER 180SC	CHC64M18	CH-C 6.4MM LARGE CHAMFER 180SC
7mm (.276)	BC7M18	BC 7MM (.276") 180SC FLEX-HONE	CHB7M18	CH-B 7MM MEDIUM CHAMFER 180SC	CHC7M18	CH-C 7MM LARGE CHAMFER 180SC
8mm (.315)	BC8M18	BC 8MM (.315") 180SC FLEX-HONE	CHB8M18	CH-B 8MM MEDIUM CHAMFER 180SC	CHC8M18	CH-C 8MM LARGE CHAMFER 180SC
9mm (.354)	BC9M18	BC 9MM (.354") 180SC FLEX-HONE	CHB9M18	CH-B 9MM MEDIUM CHAMFER 180SC	CHC9M18	CH-C 9MM LARGE CHAMFER 180SC
9.5mm (.375)	BC95M18	BC 9.5MM (.375") 180SC FLEX-HONE	CHB95M18	CH-B 9.5MM MEDIUM CHAMFER 180SC	CHC95M18	CH-C 9.5MM LARGE CHAMFER 180SC
10mm (.394)	BC10M18	BC 10MM (.394") 180SC FLEX-HONE	CHB10M18	CH-B 10MM MEDIUM CHAMFER 180SC	CHC10M18	CH-C 10MM LARGE CHAMFER 180SC
11mm (.433)	BC11M18	BC 11MM (.433") 180SC FLEX-HONE	CHB11M18	CH-B 11MM MEDIUM CHAMFER 180SC	CHC11M18	CH-C 11MM LARGE CHAMFER 180SC
12mm (.472)	BC12M18	BC 12MM (.472") 180SC FLEX-HONE	CHB12M18	CH-B 12MM MEDIUM CHAMFER 180SC	CHC12M18	CH-C 12MM LARGE CHAMFER 180SC
12.7mm (.500)	BC1218	BC 1/2" (12.7MM) 180SC FLEX-HONE	CHB1218	CH-B 1/2" MEDIUM CHAMFER 180SC	CHC1218	CH-C 1/2" LARGE CHAMFER 180SC
14mm (.551)	BC14M18	BC 14MM (.552") 180SC FLEX-HONE	CHB14M18	CH-B 14MM MEDIUM CHAMFER 180SC	CHC14M18	CH-C 14MM LARGE CHAMFER 180SC
16mm (.625)	BC5818	BC 5/8" (16MM) 180SC FLEX-HONE	BC5818	BC 5/8" (16MM) 180SC FLEX-HONE	CHC5818	CH-C 5/8" LARGE CHAMFER 180SC
18mm (.709)	BC18M18	BC 18MM (.709") 180SC FLEX-HONE	BC18M18	BC 18MM (.709") 180SC FLEX-HONE	CHC18M18	CH-C 18MM LARGE CHAMFER 180SC
19mm (.750)	BC3418	BC 3/4" (19MM) 180SC FLEX-HONE	BC3418	BC 3/4" (19MM) 180SC FLEX-HONE	CHC3418	CH-C 3/4" LARGE CHAMFER 180SC
20mm (.787)	BC20M18	BC 20MM (.787") 180SC FLEX-HONE	BC20M18	BC 20MM (.787") 180SC FLEX-HONE	CHC20M18	CH-C 20MM LARGE CHAMFER 180SC
22mm (.875)	BC7818	BC 7/8" (22MM) 180SC FLEX-HONE	BC7818	BC 7/8" (22MM) 180SC FLEX-HONE	CHC7818	CH-C 7/8" LARGE CHAMFER 180SC

Additional Sizes, Grits and Abrasives Available on Special Order

BEFORE

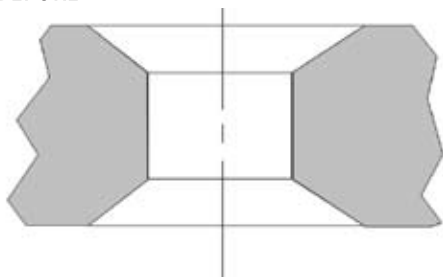

AFTER

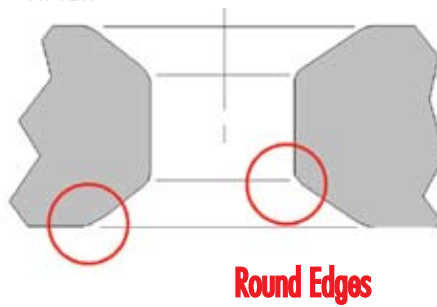

Our new series of tools is flexible and designed to polish and radius the outer corners (the intersection of the chamfer and flange face) as well as the inner corners and hole. The increased flexibility allows the tool to pass through thin web sections and polish the chamfer on the back side as well. Polished and radiused chamfer surfaces have been shown to be very beneficial on critical rotating parts.

Tool Selection

These tools are listed by nominal thru-hole diameter and produced oversized to provide the optimum cutting pressure. If a bore is between our standard sizes, the next larger tool should be selected. Each tool diameter is designed to cover three ranges of countersink sizes: .005 to .015 (per side), .015 to .030 (per side) and .030 to .050 (per side).



An ISO 9001:2008 Certified Company
BRUSH RESEARCH MANUFACTURING CO., INC.
 4642 Floral Drive, Los Angeles, California 90022
 P: 323.261.2193 F: 323.268.6587
www.brushresearch.com